

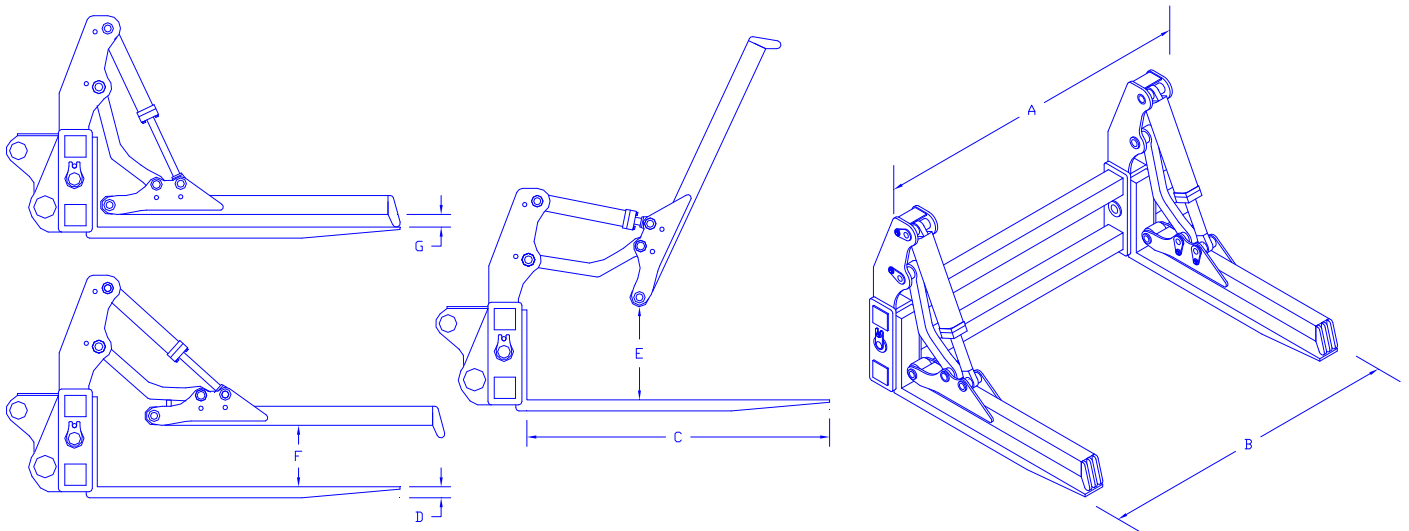

WPIF Wicker Pipe Fork

The **WPIF Pipe Forks** are designed for use where top clamps are needed. They are excellent for handling small diameter, long pipe. The wide frame gives added stability to your load. The **WPIF pipe fork** is made with the same strength and dependability as all Wicker Products. **Custom Widths and Tine reaches are available.**



Loader Class	300	400	500	600	700	800
A. Overall Width	96"	96"	120"	120"	120"	120"
B. Width across tines	94"	94"	118"	118"	118"	118"
C. Tine Reach	60-72"	72-84"	72-84-96"	72-84-96"	84-96"	96"
D. Tine size	2.5 x 7"	2.5 x 7"	3 x 8	3.5 x 8	4 x 10"	4 x 12"
E. Maximum Opening	24"	24"	29.5"	29.5"	29.5"	36"
F. Max Parallel Clamping	18"	18"	20"	20"	20"	24"
G. Min Parallel Clamping	4"	4"	4"	4"	4"	4"
Weight (lbs.)	4,200	4,800	5,300	5,800	7,950	12,500

*Custom widths and tine sizes are available

Wicker Machine Company

Hollandale, MS • 1-800-748-9476 • rwicker@wickermachinecompany.com