

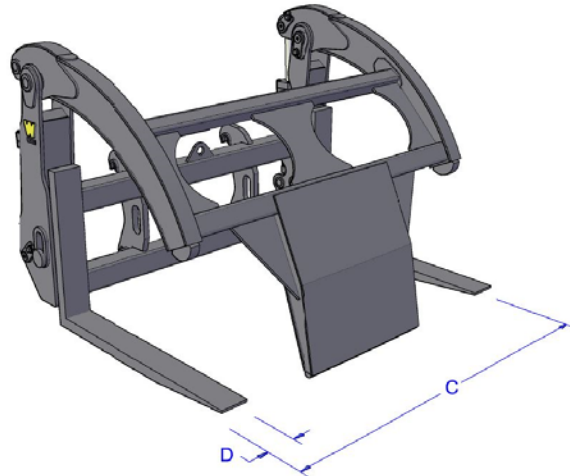

WLF General Purpose Fork

The Wicker model **WLF General Purpose Fork** is specifically designed to handle lumber, logs, and palletized material. The versatile clamp is designed to close securely on a single log or open extra wide to grip capacity loads or to handle stacks of lumber with sureness. The top clamp design along with the reinforced low profile frame, provides improve visibility for the operator and handles the greater stresses created by Z-Bar Linkage tractors. The replaceable tines are made of special nickel-chrome-molly steel to provide higher impact value and are far more resistant to fatigue failure than standard carbon steel heat treated tines. The tines are vertically self-adjusting and manually horizontally adjustable. Our severe-duty cylinders feature bolted cylinder heads for easy maintenance, case hardened bushings, stress-proof pins, inducted hardened chrome plated piston rods and high-strength stress relieved tubing, making them the best available in the industry. **Custom maximum and Minimum overall widths are available on this model.**

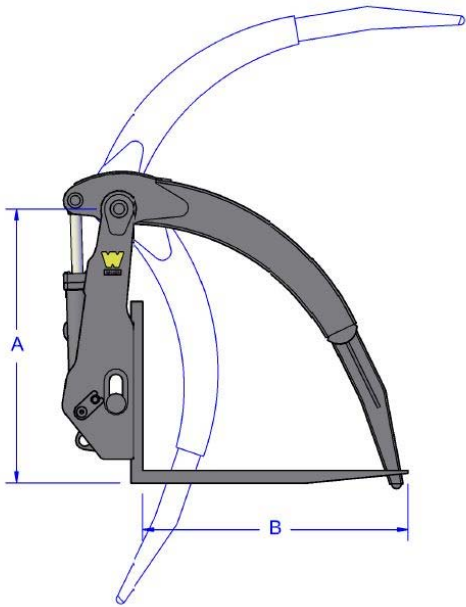

Loader Class:	200	300	400	500	600	700
A. Back Height	57"	57"	57"	60"	60"	60"
B. Tine Length	48"	48"	48"	48-60"	60-72"	72-84"
C. Maximum Width	80"	80"	85"	95"	95"	95"
D. Tine width	7"	7"	7"	8"	8"	10"
Weight (Lbs.)	3,550	3,910	4,140	5,250	5,500	7,200

Wicker Machine Company

Hollandale, MS 38748 • 662-827-5434 • 1-800-748-9476