



# WE-2XC Millyard Fork



The Wicker model [WE-2XC Millyard Fork](#) with its exceptional strength and uncompromising quality is designed to unload entire truck loads in a single pass and yet have the flexibility to sort logs and feed the mill. The tines, made of solid T-1 material, offer maximum strength and excellent resistance to impact and abrasion. The entire fork is made of high-strength steel to provide years of trouble free service. Optional wear plates are also available. Designed with an offset frame and Split Clamp the [WE-2XC Millyard Fork](#) can straddle the standards of a log trailer. This allows the unloading of double stacked bunks without damaging the trailers.

The Wicker [WE-2XC Millyard Fork](#) offers unmatched performance and reliability to reduce cost, and maximize profits.

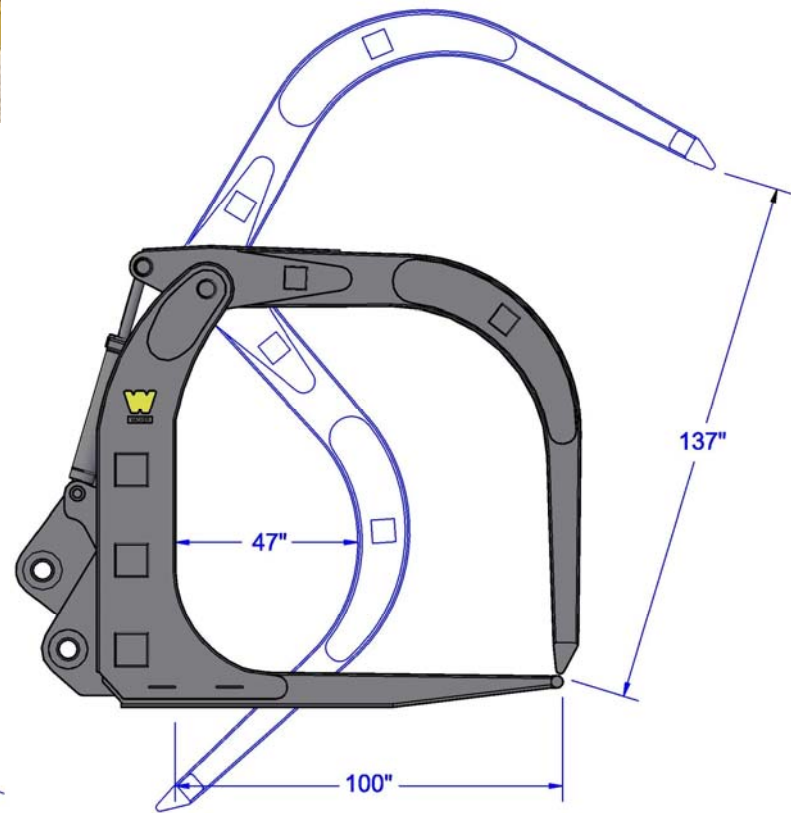
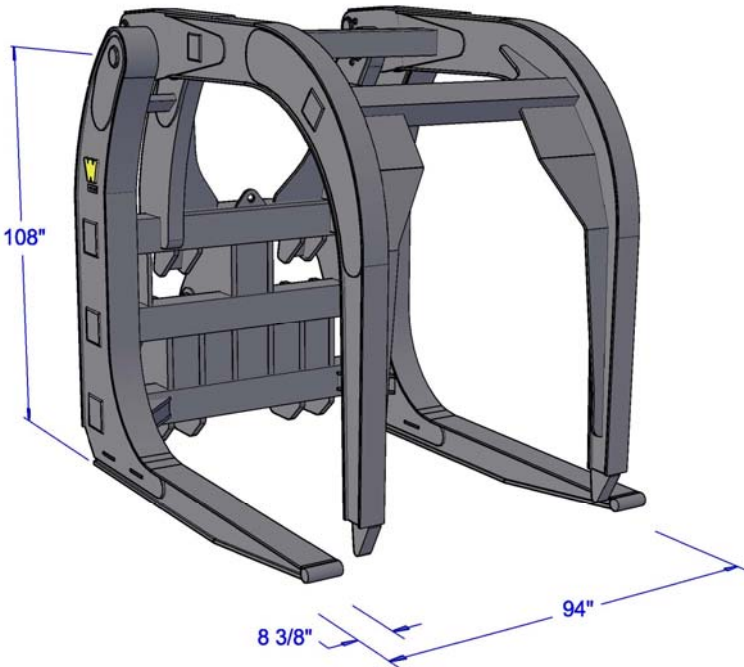

\*Custom widths are available

## *Wicker Machine Company*

Hollandale, MS 38748 • 662-827-5434 • 1-800-748-9476